

# MANUAL DE INSTRUCCIONES INSTRUCTION MANUAL

FILTRO MICRO RADIAL OFF-LINE NTF®

**SERIE**  
**OLFS**

**OLFS-29/1**

**OLFS-58/1**



Felicidades con su compra de este filtro Micro Radial Offline NTF®. Para garantizar un rendimiento óptimo de este sistema de filtración, por favor lea atentamente este manual.

1. Introducción	pág. 2
2. Descripción general	pág. 2
3. Propósito	pág. 2
4. Normas de seguridad, riesgos y advertencias	pág. 2
5. Instrucciones de uso	pág. 3
6. Transporte , almacenamiento y eliminación	pág. 3
7. Instalación y montaje	pág. 4
8. Instrucciones de mantenimiento	pág. 5
9. Garantía	pág. 6
10. Esquema hidráulico	pág. 7
11. Especificaciones técnicas de sistema de filtro	pág. 8
12. Especificaciones técnicas de la bomba	pág. 9
13. Especificaciones técnicas del motor	pág. 10
14. Declaración conformidad UE	pág. 28

Este sistema de filtración fuera de línea NTF (OLFS) se puede aplicar para la re-circulación de fluidos en cualquier sistema hidráulico, lubricante, de transmisión y combustible. La unidad ha sido equipada con un motor y una bomba de engranaje, garantizando así que la presión y las especificaciones del sistema permanezcan dentro de los límites establecidos por la fábrica. El objetivo de la OLFS es recircular el fluido bombeándolo desde un depósito o reservorio pasarlo a través del filtro y devolverlo al depósito. Al final se obtiene un fluido más limpio que conduce a menos disfunciones y ahorros de costes.

## 2. DESCRIPCIÓN GENERAL

El OLFS ha sido modulado en un colector, en el que todos los canales han sido integrados, minimizando así el riesgo de fugas. La principal ventaja de la unidad OLFS es que el proceso de filtración tiene lugar bajo un flujo y presión constantes. Debido a esto, su eficiencia es 10 veces mayor que la de cualquier sistema de filtro en línea. Los resultados son:

- Mayor nivel de limpieza en el fluido
- Menos anomalías del sistema en el que está montado el OLFS
- Menor desgaste del sistema en el que está montado el OLFS.
- Tiempo de vida prolongado del sistema en el que está montado el OLFS.
- Menor consumo, y
- Mayor aporte al medio ambiente.

El OLFS está marcado con  y se ha construido de acuerdo con la directiva de maquinaria CE norma.

## 3. PROPOSITO

Este sistema de filtro OLFS está especialmente diseñado para la filtración de depósitos de aceites hidráulicos, y lubricantes. Al filtrar combustible es muy recomendable instalar un separador de agua en la línea de succión. Como los cartuchos de filtro NTF son higroscópicos, el contenido de agua en el combustible puede causar que los elementos se saturen prematuramente.

## 4. NORMAS DE SEGURIDAD, RIESGOS Y ADVERTENCIAS

Tenga en cuenta lo siguiente cuando instale la unidad OLFS:

- Antes de montar, conectar o dar servicio a la unidad OLFS, asegúrese de que la aplicación, en la que se instale el OLFS, sea segura para trabajar. Si es necesario, apague la electricidad. Asegúrese de que no hay presión de aceite y/o combustible en las líneas. Si hay presión, bájela a 0 Bar.
- Utilizar mangueras adecuados para la aplicación (hidráulica o combustible). Deben estar equipados con los conectores apropiados. **No utilice mangueras para aplicaciones de baja presión.**
- Asegúrese de que la línea de retorno del OLFS depósito no tenga presión. **No utilice líneas de retorno existentes.**
- Utilice los materiales de conector apropiados para la aplicación (hidráulica o combustible). **¡No utilice cinta o líquido sellador!**
- Al arrancar el sistema, asegúrese de que el motor eléctrico esté girando en el sentido correcto (sentido horario).
- Al reemplazar los elementos del filtro o cuando ocurren derrames, use el equipo de seguridad personal, como se prescribe en la hoja de datos de seguridad del material.



La instalación de esta unidad sólo está permitida a los ingenieros profesionales certificados. En caso de reclamaciones de garantía se solicitarán certificados.



La unidad debe estar debidamente conectada a tierra para evitar estática.



Antes de encender la unidad, compruebe **SIEMPRE** que no hay restricciones en la línea de succión y retorno. En el caso de que las válvulas estén instaladas en la línea de aspiración y / o retorno de la unidad de filtro, estas válvulas debe abrirse antes de encender la unidad.



Cuando reemplace los elementos filtrantes o cuando se produzca derrame, use el equipo de seguridad personal, como se indica en la Hoja de Datos de Seguridad del Material. Consulte también las normas de seguridad personal en el sitio.

## 5. INSTRUCCIONES DE USO

El filtro funciona cuando el motor está funcionando. La instalación debe ser realizada por ingenieros eléctricos certificados. El usuario es responsable del cableado eléctrico y de la instalación de la unidad de filtro. El usuario debe determinar las pautas apropiadas en cuanto a cuándo y cómo encender y apagar la unidad. Encontrará más información al respecto en el número 13 "Especificaciones técnicas del motor"

## 6. TRANSPORTE, ALMACENAMIENTO Y ELIMINACIÓN

Esta unidad OLFS ha sido cuidadosamente embalada para evitar daños durante el transporte normal. Si su unidad OLFS llega dañada, por favor tome fotos de los daños ocurridos y envíelos con una descripción a su distribuidor NTF®, para que la unidad dañada pueda ser reemplazada rápidamente. No existen otros requisitos especiales para el transporte o almacenamiento.

Cuando se desecha la unidad OLFS o el elemento filtrante, se deben tener en cuenta las regulaciones locales para la eliminación de desechos químicos

- Antes de conectar y montar la unidad OLFS, asegúrese de que la máquina en la que el OLFS se instalará es segura para trabajar. Si es necesario, apague la electricidad y garantice la presión del fluido. Si hay presión, debe reducirla a 0 bar.
- Monte el sistema de filtrado en un lugar libre de vibraciones.
- Mantener las mangueras tan cortas como sea posible. No doble o tense las mangueras.
- Asegurar que haya suficiente espacio para poder cambiar el cartucho del filtro.
- Asegúrese de que el manómetro esté bien legible.
- El sistema de filtro debe ser instalado de tal manera que haya suficiente espacio disponible para conectar el equipo de análisis de aceite para las conexiones de muestra.
- La conexión de la unidad OLFS debe ser realizada por personal capacitado.
- En primer lugar montar un conector en el lado de la succión de la bomba y en el canal de retorno del colector. Ajuste la manguera o tubería a estos conectores después.
- Crear una manguera de succión del depósito al motor de Unidad OLFS. Asegúrese de que el puerto de succión en el depósito este siempre por debajo del nivel mínimo del fluido.
- **Para establecer la línea de succión usar mangueras (diámetro de 10 mm) adecuados para la aplicación (hidráulica o combustible). Deben estar equipados con los conectores apropiados. No utilizar mangueras para aplicaciones de baja presión.**
- El puerto de retorno del colector al depósito debe estar conectado sin presión. **No utilizar líneas de retorno existentes.**
- Asegúrese de que el líquido fluya de regreso al depósito por debajo del nivel mínimo. Localice el puerto de retorno en el depósito de tal manera que haya una correcta circulación. Los puertos de succión y retorno no deben estar muy juntos.
- **Para establecer la línea de retorno usar mangueras hi(diámetro de 19 mm) adecuados para la aplicación (hidráulica o combustible). Deben estar equipados con los conectores apropiados. No utilizar mangueras para aplicaciones de baja presión. ¡Mantener la línea de retorno lo más corta posible!**
- **Utilice los materiales de conector apropiados para la aplicación (hidráulica o combustible).** ¡No utilice cinta adhesiva o líquido de sellado!
- Asegúrese de que la conexión eléctrica cumple con las normas locales de seguridad y de instalación.
- **Antes de encender la unidad, compruebe SIEMPRE que no hay restricciones en la línea de succión y retorno.**
- **En el caso de que las válvulas estén instaladas en la línea de aspiración y / o retorno de la unidad de filtro, estas válvulas deben estar abiertas antes de encender la unidad.**
- Al arrancar el sistema, asegúrese de que el motor esté girando en el sentido correcto (sentido horario). Esta dirección también está marcada con una flecha en el motor. El control de la dirección de rotación se puede hacer fácilmente observando el ventilador de refrigeración del motor. La dirección de rotación depende de las conexiones de cableado como se muestra en el punto 12 "Motor de especificaciones técnicas". Evitar el acceso de cualquier agua, suciedad o polvo de acceso en el motor eléctrico.
- Después de encender el sistema y después de la primera hora de funcionamiento, compruebe si hay fugas o sonidos anormales en el sistema. Cuando el sistema muestre fugas o cualquier sonido anormal, apáguelo inmediatamente. La causa debe ser determinada y remediada antes de cualquier otra operación.
- Usando las conexiones para contador de partículas en el colector de admisión, asegurarse que la línea de retorno este sin presión.

El mantenimiento requerido en una unidad OLFS consiste en el cambio oportuno de los elementos filtrantes (cartuchos). El cambio de estos debe realizarse de la siguiente manera:

- Utilice únicamente cartuchos originales de filtro NTF®.
- Utilice únicamente las piezas de repuesto suministradas.
- El cartucho del filtro debe ser reemplazado cuando el manómetro de la temperatura de funcionamiento indique 5 bar, o cada 6 meses.
- Chequee la presión en el depósito. Alivie la presión del sistema cuando sea necesario.
- Asegúrese de que el sistema de filtrado este sin presión cuando se cambie el cartucho.
- Retire el cartucho y el O-ring de la funda plástica.
- Retire la tapa del sistema y sacar la placa de presión con el resorte.
- Retirar el cartucho utilizado y colocarlo en una bolsa de plástico para su eliminación adecuada. Coloque el cartucho nuevo dentro del filtro y luego la placa de presión con el resorte en el cartucho del filtro. Reemplace el sello retenedor O-ring, limpie las superficies de sellado y ponga la tapa sobre el sistema de filtro. Apriete los tornillos de hexágono interior con un par de mínimo y máximo de 9 Nm 12 Nm.
- Inicie el sistema hasta que haya alcanzado su temperatura de funcionamiento y verifique si hay fugas.
- Verifique el nivel de aceite en el sistema y aumentar la cantidad que sea necesaria.
- Compruebe si el fluido pasa por el bypass correctamente. Si las mangueras y la carcasa del filtro se calientan, el filtro funciona correctamente.

### 1. SISTEMA DE FILTRACIÓN

NTF® otorga 3 años de garantía limitada en la cubierta del filtro (excluyendo los sellos/caucho) desde la fecha de la factura. En el supuesto caso de que el comprador encuentra un defecto, lo deberá notificar a su distribuidor de filtros NTF®. Si el defecto está justificado, la cubierta del filtro NTF® será reemplazada o reparada de forma gratuita. Cualquier reclamo sobre la cubierta de los filtros NTF® deberá ser dirigido directamente al distribuidor de filtros NTF®. El reclamo debe contener una descripción clara de los resultados obtenidos, incluyendo fotos y especificaciones de la solicitud, junto con una copia de la factura.

### 2. PROLONGACIÓN DE LA VIDA DEL ACEITE/TIEMPOS DE CAMBIOS DE ACEITE

Cuando el filtro es correctamente instalado, NTZ® garantiza la operación de filtrado óptimo del filtro NTF® y los efectos positivos para el equipo. El tiempo para realizar los cambios de aceite se pueden prolongar y llegan a darse con el uso adecuado del sistema NTF®. No obstante, la condición del aceite, los tiempos en los cambios de aceite depende del fabricante original del equipo, de las condiciones de operación, selección del aceite/lubricante y el tipo de sistema. Debido a las condiciones que se encuentran fuera del control de NTF®, la prolongación de cualquier cambio de aceite queda a discreción del cliente. El cliente deberá realizar periódicamente análisis de aceite para asegurar que la condición de éste es el recomendado en las especificaciones establecidas por el equipo original/fabricante de aceite. Con una solicitud previa, NTF® puede ayudar en esta actividad.

### 3. GARANTÍA DEL EQUIPO

En el improbable caso de daño material en el equipo, NTF® garantizará la totalidad de los costos de reparación bajo las siguientes condiciones, (Documentación que es total responsabilidad de quien hace el reclamo):

- Si al equipo se le ha dado un apropiado mantenimiento y trabaja en buen estado al momento de la instalación, lo cual puede ser demostrado mediante las copias del historial del mantenimiento y reparación de los equipos.
- Si el filtro NTF® fue instalado por un mecánico certificado.
- El usuario debe demostrar que el daño en el dispositivo se debe al mal funcionamiento de un sistema de filtro NTF®, con una correcta instalación y habiéndolo proporcionado el uso adecuado.
- El cliente debe demostrar con datos reales o con un programa de cambios de aceite con períodos prolongados (datos históricos) que el aceite o lubricante en el dispositivo estaba dentro de las especificaciones de uso apropiado al momento de producirse la falla.

### 4. RESPONSABILIDAD

La garantía y cobertura de NTF® arriba mencionada no se extiende más allá (como consecuencia de) defectos en el filtro NTF®. Daños como resultado por terceras causas así como errores durante la instalación, montaje incorrecto en el circuito de lubricación, o por error en el montaje del dispositivo o mangueras, no son cubiertos ni por esta garantía ni por la cobertura de productos NTF®.

Con respecto al montaje de piezas proporcionadas por NTF®, la garantía aplicable es aquella proporcionada por el productor/proveedor de las partes instaladas, la cual es traspasada por NTF® al cliente. La responsabilidad es limitada al monto mencionado en la póliza de seguro sobre coberturas de riesgo que NTF® ha concluido con N.V. Interpolis. Ningún reclamo puede exceder los €2'500.000,00 (Dos millones quinientos mil euros). El monto máximo de cobertura anual por daños no deberá exceder los €5'000.000,00 (cinco millones de euros).

### 5. POLÍTICA SOBRE LA ANULACIÓN DE GARANTÍA

La garantía no se aplica (es anulada) por el usuario, siempre y cuando:

- El filtro NTF® es manipulado sin el debido cuidado o en contradicción con las instrucciones de uso de los filtros NTF®, o si el filtro es usado con otro propósito que no sea el especificado.
- Se hayan usado cartuchos genéricos y no los originales de NTF®.
- Una factura de compra con fecha no válida/certificado de garantía no es aplicable.
- Si el defecto o daño es el resultado de un desastre natural, por accidente, mal uso, o incorrecto uso, o por alguna causa externa, por lo que NTF® no es responsable.

En caso de disputa legal se aplica la legislación Holandesa.

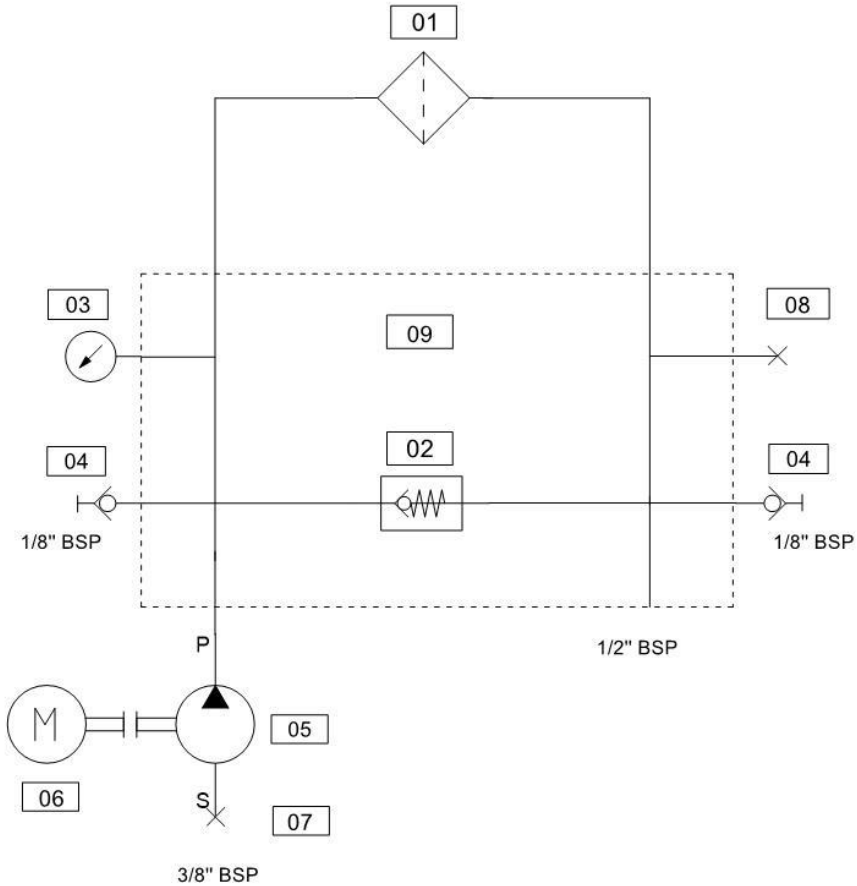

- 01. Microfiltro
- 02. Válvula de retención 5,5 bar
- 03. Manomètre
- 04. Punto de conexión para contador de partículas o muestreo
- 05. Bomba de engranajes hidráulica
- 06. motor eléctrico
- 07. Punto de conexión Lado de succión
- 08. Regreso al tanque
- 09. Colector

Tipo de filtro	OLFS-29/1	OLFS-58/1
<b>Bomba:</b>	Bomba de engranajes	Bomba de engranajes
Desplazamiento	- Varias posibles bombas -	
Lado de la conexión succión	3/8 BSP d.i.	3/8 BSP d.i.
Diámetro de manguera de succión	10 mm	10 mm
Sellos	Buna NBR	Buna NBR
Temperatura máx.	80 °C	80 °C
<b>Motor eléctrico:</b>		
Fuente de alimentación	- Varias posibles tensiones -	
<b>Filtro / colector:</b>		
Eficiencia de filtrado	Beta ( $\beta$ ) 4 > 10649	Beta ( $\beta$ ) 4 > 10649
Dimensiones del elemento filtrante	Ø 78 x 300 mm	Ø 78 x 600 mm
Caudal nominal	- depende de la bomba -	
Material filtro	Aluminio anodizado	
Máx. presión filtro	25 Bar	25 Bar
Temperatura máx.	80 °C	80 °C
Máx. Viscosidad	- dependiendo de la aplicación -	
Indicador	Manómetro	Manómetro
Conexión retorno	1/2 BSP d.i..	1/2 BSP d.i.
I.D. manguera de retorno	19 mm	19 mm
Sellos	Buna NBR	Buna NBR
Configuración de bypass	5.5 Bar	5.5 Bar
Conexiones para contador de partículas	1/8 BSP > M16X2	1/8 BSP > M16X2
Peso	21 kg	23,7 kg
Dimensiones (hwxwd)	500x340x190 mm	800x340x190 mm
Volumen en cárter (directivo)	- dependiendo de la aplicación -	





**IEC60034  
AS NZS 1359/2004  
GB755**

## **Low Voltage Motors**

INSTALLATION AND MAINTENANCE  
INSTRUCTIONS FOR ELECTRIC MOTORS

**WONDER<sup>®</sup>**

- IE1
- IE2
- IE3

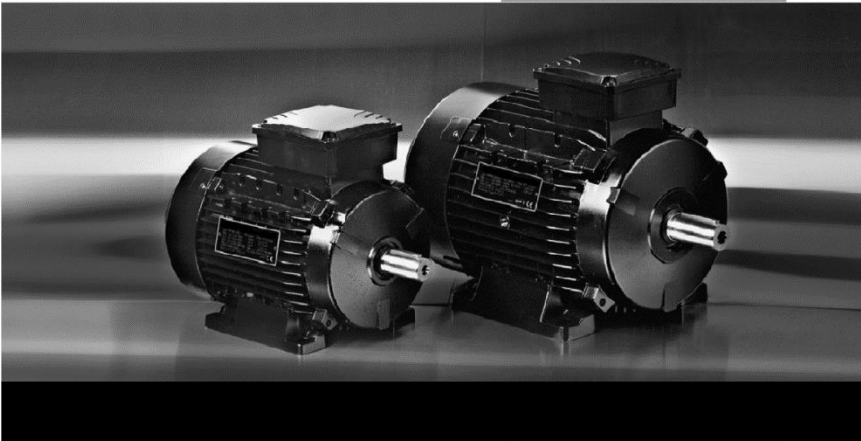

**CE** RoHS ISO9001 ISO14001

## CONTENTS

	Page
Introduction.....	2
Electro-magnetic compatibility.....	2
1. Safety warning.....	2
1.1 Danger.....	2
1.2 Standards and specifications.....	3
2 Storage and installation.....	4
2.1 Control.....	4
2.2 Storage procedure.....	4
2.3 Installation.....	4
3 Operation.....	6
3.1 Initial Controls.....	6
3.2 Control of Design Data.....	7
3.3 Starting.....	8
3.4 Conditions of Use.....	8
4 Maintenance.....	9
4.1 Inspection.....	9
4.2 Lubrication.....	10
4.3 Disassembling and Reassembling.....	10
4.4 Bearing Replacement.....	10
4.5 Repairs and Overhuals.....	11
5 Troubleshooting.....	12
Table.....	15

2010



## Introduction

The electrical machines referred to in these Instruccions are intended as components for use in industrial areas. The information contained in this documentation is designed for use by qualified personnel who are familiar with the current rules and regulations in force. They are not intended to replace any installation regulations issued for safety purposes. In terms of Directive 89/392/CEE low voltage motors are to be considered as components to be installed on machines. Commissioning is forbidden until the final product has been checked for conformity.

### Electro-magnetic compatibility

Low voltage induction motors, if installed correctly and connected to the power supply, respect all immunity and emission limits as set out in the regulations relating to electro-magnetic compatibility (EMC "Generic Standard" for industrial environments).

In the case of supply by means of electronic impulse (inverters, soft starters etc.), all verifications and any modifications necessary to ensure that emission and immunity Limits stated within the regulations are respected, are the responsibility of the installer.

### Motors for classified areas

Motors to be used in dangerous areas are designed in compliance with European standards, using protection methods that are suitable for guaranteeing safety in areas subject to risk of fire and explosion. Where these motors are used improperly or modified their safety may be impaired.

## 1. General safety warnings

### 1.1 Danger

Rotating electric machines are dangerous. Therefore:

- improper use
- removal of protection and disconnection of protection devices
- Lack of inspection and maintenance can cause serious harm.

The personnel must be informed of any danger caused by contact with:

- ⚠ - live parts
- ⚠ - rotating parts
- ⚠ - hot surfaces. In normal working conditions the motor exceeds 50 °C.

The safety manager must ensure and guarantee that:

- the machine is moved, installed, put in service inspected, maintained and repaired only by qualified personnel, who should have:
  - specific technical training and experience
  - knowledge of technical standards and applicable laws
  - knowledge of general safety regulations as well as national, local and installation regulations
  - ability to recognize and avoid all possible dangers.

**Work on the electric machine should be carried out upon authorization of the safety manager after having ensured that:**

- a) the motor has been disconnected from the power supply and that no parts of the motor including auxiliary parts are live
- b) discharge of the capacitor has been done for single phase motors
- c) the motor is completely stopped and there is no danger of accidental restarting
- d) the right precautions against faulty braking operations have been taken for self-braking motors

⚠ where thermal protection with automatic reset is used care must be taken to ensure automatic restart cannot occur. Since the electric machine referred to is intended to be used in industrial

areas, additional protective measures must be taken and guaranteed by the person who is in charge of installation where more stringent protective measures are needed.

## 1.2 Standards and specifications

Title	INTERNATIONAL	EU	I	GB	F	D
	IEC	CENELEC	CEI-EN	BS	NFC	DIN/VDE
Electrical rotating machines/rated operation and characteristic data	IEC 60034-1	EN 60034-1	CEI-EN 60034-1 (CEI 2-3)	BS 4999-1 BS 4999-69	NFC 51-100 NFC 51-111	VDE 0530-1
Methods for determining losses and efficiency of rotating electrical machinery	IEC 60034-2	EN 60034-2	CEI-EN 60034-2 (CEI 2-6)	BS 4999-34	NFC 51-112	VDE 0530-2
Protection types of rotating electrical machines	IEC 60034-5	EN 60034-5	CEI-EN 60034-5 (CEI 2-16)	BS 4999-20	NFC 51-115	VDE 0530-5
Cooling methods of rotating electrical machines	IEC 60034-6	EN 60034-6	CEI-EN 60034-6 (CEI 2-7)	BS 4999-21	IEC 34-6	DIN IEC 34-6
Construction types of rotating electrical machines	IEC 60034-7	EN 60034-7	CEI-EN 60034-7 (CEI 2-14)	BS 4999-22	NFC 51-117	DIN IEC 34-7
Terminal markings and direction of rotation for electrical machines	IEC 60034-8	EN 60034-8	CEI 2-8	BS 4999-3	NFC 51-118	VDE 0530-8
Noise emission, limit values	IEC 60034-9	EN 60034-9	CEI-EN 60034-9 (CEI 2-24)	BS 4999-51	NFC 51-119	VDE 0530-9
Start-up behaviour of squirrel-cage motors at 50 Hz up to 660V	IEC 60034-12	EN 60034-12	CEI-EN 60034-12 (CEI 2-15)	BS 4999-112	IEC 34-12	VDE 0530-12
Vibration severity of rotating electrical machines	IEC 60034-14	EN 60034-14	CEI-EN 60034-14 (CEI 2-23)	BS 4999-50	NFC 51-111	DIN ISO 2373
Fixing dimensions and outputs for IM B3	IEC 60072	EN 50347	IEC 60072	BS 4999-10	NFC 51-104/110	DIN 42673
Fixing dimensions and outputs for IM B5, IM B14	IEC 60072	EN 50347	IEC 60072	BS 4999-10	NFC 51-104/110	DIN 42677
Cylindrical shaft ends for electrical machines	IEC 60072	EN 50347	IEC 60072	BS 4999-10	NFC 51-111	DIN 748-3
Electrical equipment for hazardous areas General provisions	IEC 60079-0	EN 60079-0	(CEI 31-8)	BS 5501-1	NFC 23-514	VDE 0171-1
Electrical equipment for hazardous areas Flame-proof enclosure "d"	IEC 60079-1	EN 60079-1	(CEI 31-1)	BS 5501-5	NFC 23-518	VDE 0171-5
Electrical equipment for hazardous areas Increased safety "e"	IEC 60079-7	EN 60079-7	(CEI 31-7)	BS 5501-6	NFC 23-519	VDE 0171-6
Checking and maintenance of electrical systems in places in danger of explosion due to the presence of gas	IEC 60079-17	EN 60079-17	CEI EN 60079-17	----	----	----
Electrical systems in places in danger of explosion due to the presence of gas	IEC 60079-14	EN 60079-14	CEI EN 60079-14	----	----	----
Classification of dangerous places due to the presence of gas	IEC 60079-10	EN 60079-10	CEI EN 60079-10	----	----	----
Checking and maintenance of electrical systems in places in danger of explosion due to the presence of dust	IEC 61241-17	EN 61241-17	CEI EN 61241-17	----	----	----
Electrical systems in places in danger of explosion due to the presence of dust	IEC 61241-14	EN 61241-14	CEI EN 61241-14	----	----	----
Classification of dangerous places due to the presence of dust	IEC 61241-10	EN 61241-10	CEI EN 61241-10	----	----	----

## 2. Storage and installation

### 2.1 Control

The motors are shipped ready for installation. Upon receipt, remove packaging and turn the shaft to check the motor has not been damaged, also check all physical aspects of the machine for damage. In the case where the machine is damaged, an immediate notification must be given in writing by the storeman and the representative of the carrier to Wonder within 3 days.

### 2.2 Storage procedure

#### 2.2.1 Storage conditions

If the motors are not used immediately, they should be stored in a clean, dry temperature environment free of vibrations and protected from the weather. (If stored below  $-15^{\circ}\text{C}$ , and before starting, the motor temperature must be restored to the permissible working temperature range (i.e.  $-15^{\circ}\text{C} \rightarrow 40^{\circ}\text{C}$ ). In this case, it is necessary to specify these particular storage conditions during the ordering stage so that proper precautions can be taken during building and packaging.

#### 2.2.2 Checking bearings

When the motors are stored properly, no maintenance is needed. However, it is a good idea to turn the shaft by hand every three months. After storage of over one year, motors with unshielded bearings (usually such motors have a lubricator and bear a lubrication plate). It is advisable to check the condition of the lubrication and motor components.

#### 2.2.3 Checking insulation

Before installation, check the motor windings using the appropriate instruments to ensure the condition of the insulation between phases and between phase

and earth are of the correct resistance values.

**⚠** Do not touch the terminals during and immediately after measuring as they are live. If the insulation resistance value is less than 10 megaohm or after storage in a damp environment, the motors must be dried in an oven for about 8 hours by gradually bringing the temperature up to  $100^{\circ}\text{C}$ . To ensure that the dampness has been completely expelled, the motors must be dismantled.

#### 2.2.4 Operating precautions

All operations listed above must be carried out by qualified personnel. In case of flame-proof motors, it is necessary:

- to be very careful the flame-proof characteristics are not altered
- to have the procedure described in point 2.2.2 carried out by authorized repair shops
- to be aware that dismantling or opening of the motor during the warranty period without authorization of Wonder may invalidate the warranty.

### 2.3 Installation

**⚠ ⚠** Work on the electric machine must be carried out when the machine has stopped and been disconnected from the power supply (including auxiliary parts, such as anticondensation heaters).

#### 2.3.1 Lifting

Before using the lifting rings, make sure they have been tightened.

**⚠** The lifting rings are big enough to bear the weight of a single motor, therefore they must not be used to lift the equipment connected to the motor.

In environments where the temperature is below  $-20^{\circ}\text{C}$ , these lifting rings should

be used with caution as they could break at low temperatures and cause damage.

### 2.3.2 Assembly of connecting device

Fitting pulley, coupling or gear to the motor shaft must be carried out with care to ensure no damage is caused to the bearing. Remove the protective paint finish from the shaft and smear with oil then fit the device, heating before fitting if possible to ensure an easy fit.

Any component that is assembled on the motor shaft must be accurately balanced.

The motor is normally balanced using a half key and the letter H is punched on the shaft.

Fitments not balanced properly can cause anomalous vibrations during operation that jeopardises the proper working of the motor and drastically reduces its life.

### 2.3.3 Direct connection

Use couplings that have been made and balanced perfectly align the motor shaft and the operating machine precisely. Inaccurate alignment may cause vibrations and damage to the bearings or breakage of the shaft end.

### 2.3.4 Connection by means of pulley

Check that alignment with the pulley of the operating machine has been carried out perfectly. The tension of the belts must be enough to avoid slipping. Excessive tension of the belts causes harmful radial loads on the motor shaft and bearings, reducing their life.

It is advisable to assemble the motor on belt-tensioning slides in order to regulate tension of the belts exactly.

⚠ Connection with belts must be such as to avoid accumulation of static charges in the moving belts which could cause sparks.

### 2.3.5 Connection to power supply

Use cables with sufficient section to bear the maximum current absorbed by the motor, avoiding overheating and /or drops in voltage. Connect the cables to terminals by following the instructions on the plate or on the diagram included in the terminal box. Check that terminal nuts are tightened.

⚠ **Connections to the terminals must be made in order to guarantee safe distances between live uncovered parts.**

⚡ Earthing is through the screw located inside the terminal box. Flame-proof motors are provided with a second earth stud located on the motor casing outside the terminal box. Earths must be of sufficient size and installed according to relevant standards. The area of contact of connections must be cleaned and protected against corrosion.

When the cable inlet is made by means of a cable gland, it must be chosen properly in relation to the type of plant and type of cable used. The cable gland must be tightened so that the retaining rings create the pressure necessary to:

- a) prevent transmission of mechanical stress to the motor terminals
- b) ensure the mechanical (IP degree) protection of the terminal box.

For flame-proof motors the cable inlet must be made by complying with the regulations in point 13 of the standard IEC 60079-1. Apertures not used must

be closed in accordance with specifications in point 13 of the same standard.

When reassembling the terminal cover make sure that if there is a seal, and it is in the right place. Flame-proof motors do not have a seal so before reassembling the terminal box it is necessary to replace the layer of grease. The terminal box cover must be tightened to ensure it is properly sealed.

**2.3.6 Connection of auxiliary parts**

a) thermal protection

Check which type of protection is installed before making connections. If thermistors (PTC) are used, it is necessary to utilize a suitable relay. Do not apply a tension over 6V during the thermistor continuity test.

b) anti-condensation

If the motor is fitted with anti-condensation heaters, their power supply must be separated from that of the motor, using the terminals housed in the terminal box.

**⚠ WARNING:** the supply of the heater is always monophase and the voltage is different from that of the motor. Check that it corresponds to the one indicated on the plate.

c) auxiliary ventilation

Connect the supply of the auxiliary ventilation motor separately from that of the main motor.

**⚠ WARNING:** use a device that allows starting and operation of the main motor only when the auxiliary fan is working

**2.3.7 Fixing to the base**

The bolts fixing the motor to the base must be fitted with washers that they ensure adequate load distribution.

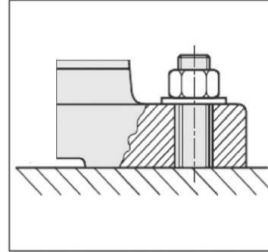

**3. Operation**

**⚠** it is the responsibility of the installer to establish the motor's fitness to be used in a certain plant, after analysing the characteristics of danger existing in the installation area with respect to current provisions of the law and to those issued for safety purposes.

**3.1 Initial Controls**

Before starting the motor it is important to check that:

- a) installation has been carried out properly
- b) the bearings have not been damaged during installation
- c) the motor base is sturdy enough and the foundation bolts have been tightened
- d) the design data corresponds to those given on the plate and in the technical documentation

**⚠** The electric motor is a component made to be mechanically connected to another machine (single or part of a plant). Consequently, it is the task of the person responsible for the installation to guarantee that during operation there is an adequate degree of protection for



people or things against the danger of accidental contact with moving parts.

### 3.2 Control of Design Data

Make sure that the motor is suited for use in the working conditions foreseen and check the following:

#### 3.2.1 Environmental conditions

- a) ambient temperature: standard closed motors can operate between  $-15^{\circ}\text{C}$  and  $+40^{\circ}\text{C}$ .
- b) altitude:  
normal motors have been designed to work between 0 and 1.000 m above sea level
- c) protection against the presence of harmful agents like: sand, corrosive substances, dust and/or fibre, water, mechanical stress and vibrations
- d) mechanical protection:  
installation inside or outside considering the harmful effects of the weather, the combined effect of temperature and humidity and the formation of condensation
- e) adequate space around the motor especially on the fan side to allow proper ventilation
- f) motors mounted in the vertical, shaft down require a protective cowl over the fan inlet
- g) any danger of explosion or fire.

#### 3.2.2 Working conditions.

- a) The motor must only be assembled and operated in the construction form indicated on the motor plate.
- b) operation type:  
the motors are normally for S1 duty continuous operation
- c) load type:

carefully evaluate machines with high moments of inertia and the relative starting times

- d) for motors intended for operation in hazardous areas (Ex d or Ex e) the motor type and temperature classification must comply with the area rating
- e) for self-braking motors see the special applications envisaged in the relative catalogue.

#### 3.2.3 Electrical characteristics

- a) voltage and frequency should correspond to those on the plate
- b) motor power should be adequate as required by the load
- c) power supply protection against overloads and/or short circuits should be adequate for the nominal current and starting current
- d) for connection to control circuits follow the connection diagram supplied with motor (Table A)

 Abnormal working conditions must always be defined when placing order to ensure that the site conditions are not prejudicial to the proper operation of the machine.

#### 3.2.4 Other checks before commissioning

- Check that the motor rotates in the correct direction, and that when the inverter is activated the speed limit is not exceeded.
- Check that the motor is protected as prescribed in the standards.
- When using a star/delta starter, to avoid the risk of overloading make sure that the switch over from star to delta only takes place when the starting

current has been adequately reduced.

- Check that any auxiliary accessories are working.

### 3.3 starting

#### 3.3.1 Earthing connection

Before starting the motor ensure that the incoming supply cables are connected correctly

#### 3.3.2 Motors with auxiliary ventilation

For motors with forced ventilation by means of external ventilation make sure that the motor starter is interlocked with the contactor of the external ventilator to ensure the fan is operational.

#### 3.3.3 Start up

When all previous checks have been made satisfactorily, the motor may be started. Unless otherwise stated all motors can be direct on line started. If you intend to start the motor by means of static starters, rheostats or the star-delta system, they must be chosen and set properly to avoid incorrect functioning of the motor.

### 3.4 Conditions of Use

#### 3.4.1 Working features

Once the motor has started it is necessary to check that during operation the working conditions remain within the limits envisaged, and that the following does not occur.

- overload
- rise in environmental temperature
- excessive drop in voltage

**Every time there is a change in the working conditions, it is necessary to check that the complete fitness of**

**the motor has been maintained for the new operating conditions.**

For example:

- variation in working cycle
- the function of the motor has altered
- moving of the motor to a different environment
- moving of the motor to a higher temperature environment.

#### 3.4.2 Restarting after long rest

Before starting the motor after a long resting period, repeat the controls described in section 2.2.2 and

#### 2.2.3.

**Where supplied, heater must not be energised when the motor is running.**

#### 3.4.3 Anomalous conditions

The motor must be used only for applications it was designed for and must be utilized and controlled complying with the precautionary standards.

** If the machine shows anomalous working characteristics (greater absorption, increase in temperature, noisiness, vibrations), inform the personnel in charge of maintenance immediately.**

#### 3.4.4 Protection against overloading

In terms of the IEC.60079-14 standard all motors are to be protected using a suitable switch, such as one with a delayed trip that is triggered by the current, as well as protection in case of a phase going down. The protective device is to be set at the nominal current shown on the plate. This device must be chosen so that the motor is protected thermally if the rotor jam.

The windings connected in delta must be protected in such a way that the

switches or relays are connected in series with the winding phase. Switches are to be chosen and set taking the nominal phase current, that is, 0.58 times the motor's nominal current, as the base value.

## 4. Maintenance

**⚠ ⚠** Any operation on the motor must be carried out with the machine stopped and disconnected from the power supply (including auxiliary circuits, especially the anticondensation heaters).

Maintenance of the original characteristics of electric machines over time must be ensured by a schedule of inspection, maintenance and setting up managed by qualified technicians. The type and frequency of maintenance depends on environmental and working conditions. As a rule, it is recommended that the first inspection is made after about 500 hours of operations or within 1 year, while subsequent inspections should follow the schedules established for lubrication and general inspection.

### 4.1 Checking

#### 4.1.1 Normal working

Check that the motor works normally without anomalous noise or vibrations, If it does not, locate the cause of the anomaly.

#### 4.1.2 Cleaning the surface

Make sure that the ventilation is not obstructed. Clean the motor by removing any dust or fibre deposits from the fins and from the fan cover.

#### 4.1.3 Checking the supply and earthing cable

Check that the supply cable does not show signs of wear and that the connections are tight. Make sure that the earth and

supply cables are not damaged.

#### 4.1.4 Transmission elements

Check that the transmission elements are in perfect condition and that the screws and nuts are tight.

#### 4.1.5 Protection against water

When the motor is installed in a very damp environment or is subject to drips of water, check regularly that the seal and retaining devices work efficiently. Ensure that there are no infiltrations inside the casing or terminal box.

#### 4.1.6 Drainage devices

The motors furnished with drainage devices should be checked and cleaned regularly so that such devices continue to work properly.

#### 4.1.7 Thermal protection

Make sure that thermal protections have not cut out and have been set properly.

**⚠** The right selection and setting of thermal protections for Ex e motors is essential to guarantee the temperature class and safety against the danger of explosion.

#### 4.1.8 Unauthorized modifications

Check that no modifications have been made that alter the electric and mechanical operation of the motor.

#### 4.1.9 Painting

When the motor is installed in an environment where there are corrosive agents it is recommended to paint the motor itself to protect the outer surfaces from corrosion if necessary.

#### 4.1.10 Reconditioning operations

Every irregularity of fault found during inspection must be fixed immediately.

## 4.2 Lubrication

### 4.2.1 Permanently lubricated bearings

Motors with shielded or sealed bearings do not require lubrication. They do not require maintenance if used properly.

### 4.2.2 Bearings with lubricator

Motors with unshielded bearings are furnished with lubricators. The interval time between lubrications depends on the type of grease, environmental temperature, (any excessive working temperature) and type of operation the motor carries out. The table B show the intervals foreseen for 70°C as a working temperature of the bearings in normal operating conditions. It is recommended to use a good quality lithium based grease with great penetration capacity and high dropping point. If the velocity is different from the one given in the table, the intervals must be modified in inverse proportion.

Eg. bearing 6314 at 1.800 RPM

$$1 = \frac{1500}{1800} \times 3550 \text{ h} = 2950 \text{ h}$$

Regardless of working hours, the grease must be renewed after 1 or 2 years or during a complete overhaul. When the motor is furnished with a lubrication plate, refer to the dates shown on it.

## 4.3 Disassembling and Reassembling

**All operations must be carried out conforming health and safety regulations.**

### 4.3.1 Consulting the catalogue

Before working on the motor it is advisable

to consult the relevant catalogue and have all the tools ready.

### 4.3.2 Disconnection from power supply

Before proceeding with dismantling, the motor must be disconnected from the power supply. Make sure that the power is off, disconnect supply cables and auxiliary cables if any.

### 4.3.3 Placing on workstand

In order to work on the motor satisfactorily it should be removed from its mounting and placed on a work stand.

### 4.3.4 Disassembling procedure

Take off the fan cover by removing the screws.

Use an extractor to remove the cooling fan, Remove the end shields and withdraw the rotor being careful not to damage the windings. Precautions must be taken with flameproof motors so that the spigots on the frame and the end shields are not damaged. When the motor is dismantling and before it is reassembled it is necessary to protect the various components (particularly the bearings and windings) to avoid damage caused by dust or knocks.

### 4.3.5 Additions for self-braking motors

For dismantling for self-braking motors follow the instructions shown in the relative catalogue.

## 4.4 Bearings Replacement

### 4.4.1 Dismantling of bearings

- a) Bearings interference fit to shaft:
  - remove the bearings with the aid of a suitable extractor.
- b) Bearings interference fit to end shield:
  - heat end shield to a temperature between 140 and 160°C and then remove the bearings with the aid of

a suitable extractor.

In both cases, check that the respective housings have not been damaged. Then proceed with fitting the new bearings, these should be identical to those being replaced.

#### 4.4.2 Fitting new bearings

- a) Bearings interference fit to shaft: heat the bearings to 120-130°C and push them quickly onto the shafts. If required, use a mallet and a brass sleeve, this must rest on the inner race of the bearing. Alternatively, if it is not possible to heat the bearings, we recommend using a press and a suitable sleeve which must rest on the inner race of the bearing.
- b) Bearings interference fit to end shield: heat the end shield to a maximum temperature of 140°C, then position the bearing in its housing, push it until it rests against the snap ring.

#### 4.4.3 Checking the bearings

- a) Bearings interference fit to shaft: after assembly has been completed the inner ring of the bearing must rest against the relevant shaft shoulder.
- b) Bearings interference fit to end shield: after assembly has been completed the inner ring of the bearing must rest against the snap ring

#### 4.4.4 Reassembling the motor

Before reassembling, clean the internal parts of the motor carefully and check that the components have not been damaged. Renew the layer of grease where needed on the abutting spigots and proceed with the reassembling.

### 4.5 Repairs and Overhauls

#### 4.5.1 Spare parts

When needed, all motor components should be replaced by original spare parts. To request spare parts use the technic terms shown in the catalogues and always give:

- motor type
- serial number
- year built

#### 4.5.2 Personnel qualification - Authorized repair shops

**Overhauls and repairs must be carried out by trained personnel who guarantee restoration of the motor to its original conditions, we recommend that you contact an authorised repair agent.**

For further information please contact our sales department.

## 5. Troubleshooting

Problem	Possible Cause	Solution
The motor does not start	Fuses damaged due to overloading	Replace the fuses with similar ones of the correct size.
	Opening of the overload switch	Check and reset the switches.
	Insufficient power available	Check that the power required is as shown on the motor's plate.
	Connections incorrect	Check that the connections are as shown in the motor's connection diagram.
	Mechanical fault	Check that the motor and the machine to which it is coupled turn freely. Check the bearings and lubricant.
	Short circuit on the stator	The motor must be rewound.
	Defective rotor	Check whether the bars and the rings are broken, if necessary replace the rotor.
	One phase is down	Check the connection cables.
	Incorrect application	Check the sizing with the manufacturer.
	Overload	Reduce the load.
	Voltage too low	Make sure that the motor is powered at the voltage shown on the plate.
The motor does not reach its nominal speed or the acceleration times are too long and/or absorption excessive	Voltage drop on the line	Check the connections. Check that the cables are of the correct size.
	Excessive inertia	Check the size of the motor.
	Defective rotor	Check the state of the rotor cage. Replace the rotor if necessary.
The motor overheats when working under load	Overloaded	Reduce the load.
	Cooling fins and/or fan cover blocked by dirt	Clear the ventilation slots to ensure a continuous flow of air over the motor.
	One phase on the motor may be down	Check that all the cables are connected tightly and correctly.
	One phase on the winding is earthed	Check the winding and remove the fault.

Problem	Possible Cause	Solution
	Phase voltages asymmetrical	Check the power supply and motor -voltages and rebalance the loads.
	Duty too great	Use the motor for the service indicated on the plate.
Incorrect rotation	Incorrect phase sequence	Invert two phases.
Functioning of the protective device	The motor may have one phase down	Check the power supply.
	Wrong connection	Follow the wiring diagram for the connections and the performance data shown on the plate.
	Overloaded	Compare against the data on the plate and reduce the load if necessary.
Abnorrnal vibrations	Motor not aligned	Align the motor with the machine it controls.
	Base weak	Reinforce the base. Check the bolts.
	Coupling or pulley not balanced	Balance the device.
	Coupled machine unbalanced	Balance the coupled machine.
	Defective bearings	Replace the bearings.
	Motor balanced differently from the coupling (half key - full key)	Balance the coupling using the half key.
	Three-phase motor working with 1 phase down	Check the phases and reinstate the three-phase system.
	Excessive play on the bearings	Either: -replace the bearings -replace the shield -add a shim to the bearing seating.
Irregular noise	Fan touching the fan cover	Eliminate contact.
	Defective bearings	Replace the bearings.
Bearings overheating	Motor fitted incorrectly	Check that the motor is adequate for the type of fitting.
	Belts over-tensioned	Reduce the belt tension.
	Pulleys too far from the shaft shoulder	Move the pulley nearer to the shoulder on the motor shaft.
	Pulley diameter too small	Use a bigger pulley.
	Alignment incorrect	Correct the alignment of the motor and the machine coupled to it.

Problem	Possible Cause	Solution
	Insufficient grease	Keep the correct amount of lubricant in the bearings.
	Lubricant ineffective or contaminated	Remove the old grease, wash contaminated bearings carefully and grease with new lubricant.
	Excessive lubricant	Reduce the amount of lubricant. The bearing must not be more than half full.
	Bearing overloaded	Check the alignment and any radial and/or axial thrust.
	Bearing balls or race damaged	Replace the bearing.

## Motor spare part list

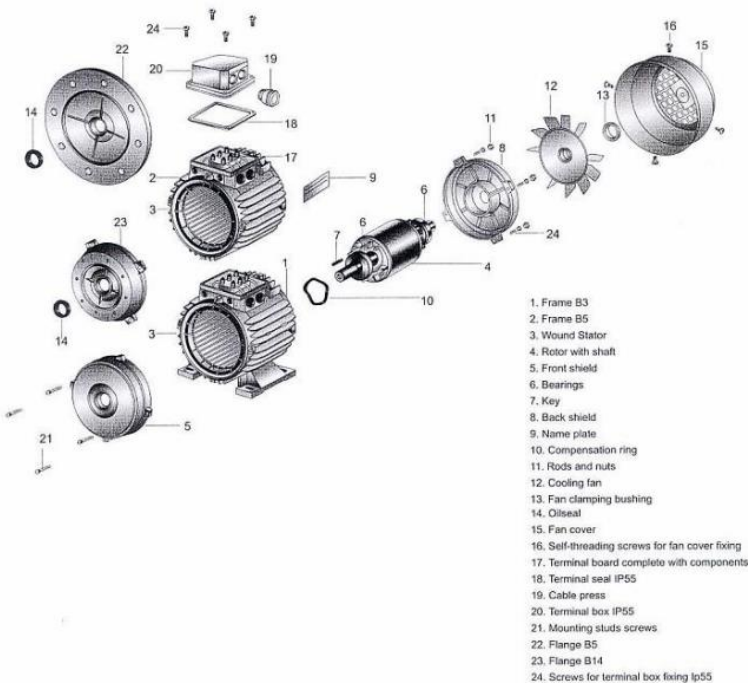



### Connecting diagrams - Table A

Connection for single speed motors:

Y-Connection

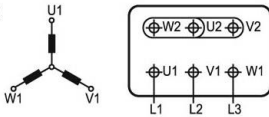

Connection-A

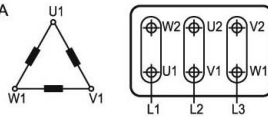

Number of pole: 2, 4, 6, 8....-Synchronous speed at 50 Hz: 3000, 1500, 1000, 750....

Two separate windings for two speed motors:

High Speed

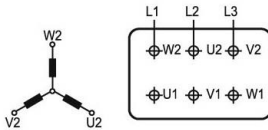

Low Speed

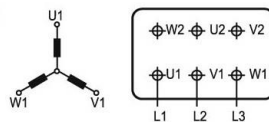

Number of pole: 2/6, 2/8, 4/6, 6/8....-Synchronous speed at 50 Hz: 3000/1000, 3000/750, 1500/1000, 1000/750....

Dahlander system for two speed motors, constant torque:

High Speed

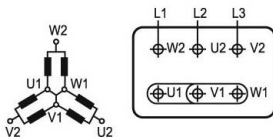

Low Speed

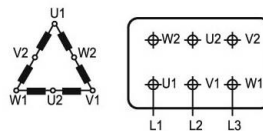

Number of pole: 2/4, 4/8 -Synchronous speed at 50 Hz: 3000/1500, 1500/750

Dahlander system for two speed motors, quadratic torque:

High Speed

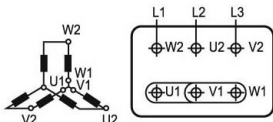

Low Speed

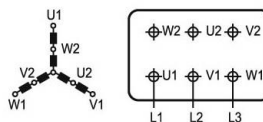

Number of pole: 2/4, 4/8 -Synchronous speed at 50 Hz: 3000/1500, 1500/750

Connection for single-phase and special motors.

For single-phase motors and motors with special connections, refer to the diagrams provided with the motor.

**Lubrication intervals in hours for unshielded bearings - Table B**

Ball bearings		Lubrication intervals in duty hours						
Frame size	Amount of grease g	3600 r/min	3000 r/min	1800 r/min	1500 r/min	1200 r/min	1000 r/min	500-900 r/min
112.132	15	4200	4800	7000	7800	8500	10000	10500
160.180	20	3200	4200	6000	7000	8000	9000	10000
200.225	25	1800	3100	5500	6500	7500	8500	9500
250.280	35	800	2000	5000	6000	7000	8000	9000
315	50	800	2000	4600	5500	6500	7500	8000
355.400	60		1000	4000	5000	6000	7000	8000

**Specification Single Fase electric motors used on OLFS Singel and Twin**

Wonder Motor Type MY=cast aluminum series	Rated output power pn kw	full-load current 220V lu A	Rated speed nN min <sup>-1</sup>	full-load power pactor cosφ	Full-load efficiency η %	locked rotor current Ia/In	locked rotor torque Ma/MN	break down torque MK/MN	moment of inertia J kgm <sup>2</sup>	net weight m kg
MY7124	0.37	3.0	1370	0.92	62	3.4	0.35	1.7	0.000513	7.0

Frame	A	AB	AC	AD	B	C	D	DH	E	F	G	H	K	KK	L	M	N	P	S	T	LC	DA	EA	GC	GB	GA	FA
71	112	136	138	110	90	45	14	M5×12	30	5	11	71	13	2-M18×1.5	250	85	70	105	9	3.5	274	14	30	16	11	16	5

**B14**

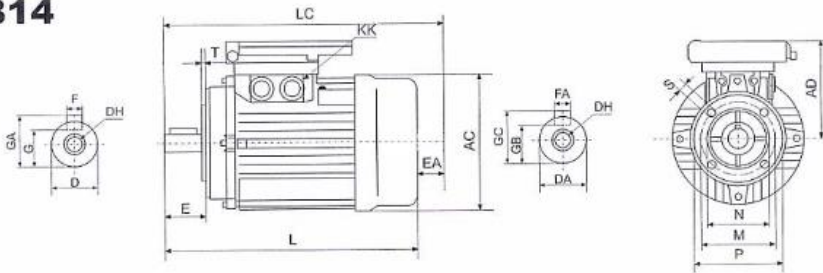

# 13. ESPECIFICACIONES TÉCNICAS DEL MOTOR



## Specification Three Fase electric motors used on OLFS Singel and Twin

Wonder Motor Type MS=cast aluminum series	Rated output power pn kw	full-load current			Rated speed n <sub>n</sub> min <sup>-1</sup>	full-load power factor cos φ	Full-load efficiency η %	locked rotor current I <sub>a</sub> /I <sub>n</sub>	locked rotor torque M <sub>s</sub> /M <sub>n</sub>	break down torque M <sub>b</sub> /M <sub>n</sub>	moment of inertia J kgm <sup>2</sup>	net weight m kg														
		380V I <sub>n</sub> A	400V I <sub>n</sub> A	420V I <sub>n</sub> A																						
MS7124	0.37	1.10	1.06	0.99	1340	0.75	67.0	5.8	2.2	2.1	0.000468	6.7														
Frame	A	AB	AC	AD	B	C	D	DH	E	F	G	H	K	KK	L	M	N	P	S	T	DA	EA	GC	GB	GA	FA
MS71	112	136	138	109	90	45	14	M5×12	30	5	11	71	13	2-M18×1.5	250	85	70	105	M6	3.5	14	30	16	11	16	5

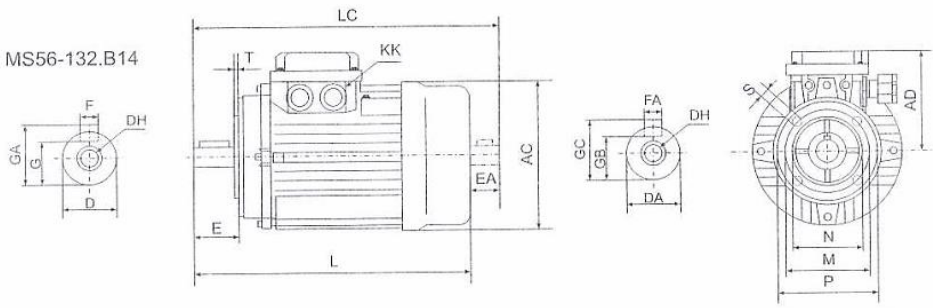

Cliente :  
Orden de compra :  
Fecha de compra :  
Fecha de entrega :

Nosotros, NTF Filter bv, declaramos, bajo su propia responsabilidad, que este producto ..... Con número de serie .....

A la que está relacionada esta declaración, cumple con todos los reglamentos apropiados y está en conformidad con:

- la Directiva 2006/42 / CE del Parlamento Europeo y del Consejo, de 17 de mayo de 2006, relativa a las máquinas y la modificación de la Directiva 95/16 / CE (Directiva).
- Directiva 94/9 / CE del Parlamento Europeo y del Consejo, de 23 de marzo de 1994, relativa a la adaptación mutua de las reglamentaciones gubernamentales de los Estados miembros relativas a aparatos y sistemas de seguridad destinados a utilizarse en lugares donde pueda producirse peligro de explosión (ATEX).
- la Directiva 2006/95 / CE del Parlamento Europeo y del Consejo, de 12 de diciembre de 2006, relativa a la adaptación mutua de las disposiciones legales de los Estados miembros relativas al material eléctrico destinado a ser utilizado dentro de los límites de tensión establecidos. (Directiva de baja tensión).

Rotterdam, Países Bajos

Fecha :  
Nombre :  
Función :